



Futurecom Systems Group, ULC

VRX1000 Installation Guide

Document: 8M087X03
Revision: R1.1
Date: March 2024

NOTES

Table of Contents

Manual Revisions	3
Table of Contents	4
Proprietary Statement	6
Commercial Warranty	7
Declaration of Conformity	8
Important Safety Information	9
Notice to Users (FCC/ISED)	10
Déclaration de Conformité	11
Informations de Sécurité Importantes	12
Avis Aux Utilisateurs (FCC/ISED)	13
Introduction	14
Installation Planning	15
Cautionary Notes & Considerations.....	15
Tools Required.....	15
Programming Details	16
Bypass Switch.....	16
Status Lights	19
Automated VR Activation (AVRA) and Primary/Secondary Preference Trigger.....	21
Mounting Instructions	23
Cautionary Notes & Considerations.....	23
Preparation.....	23
Instructions.....	23
Cable Connections	25
Cautionary Notes & Considerations.....	25
Configuration Terms:	25
VRX1000 Connections	26
In-Band VRX Filter, MSU Filter and RF Bypass Switch Connectors	27
Power Cable.....	29
HFB Fuse Holder Installation: HFB Fuse Holder is a model of in-line waterproof fuse holders.	29

HHB Fuse Holder Installation: HHB Fuse Holder is a model of in-line waterproof fuse holders.....	30
Configuration Identification	32
Standard Installation Cables.....	32
Installation Drawings	33
Configuration 1: VRX (700/800MHz, VHF or UHF) Cross-band Flat Mounted	33
In-Band RF Switching Cabling.....	34
Configuration 2: VRX (700/800MHz, VHF or UHF) In-band Flat Mounted (Non-APX 8500 MSU)	34
Configuration 3: VRX (700/800MHz, VHF or UHF) Cross-band Flat Mounted (APX8500 MSU)	34
Configuration 4: VRX (700/800MHz, VHF or UHF) In-band Flat Mounted (APX8500 MSU)	35
Auxiliary Port Options	36
In-Band Auxiliary Cabling	36
Cross-Band Auxiliary Cabling.....	36
Status Lights	37
Antenna Installation	38
Cautionary Notes & Considerations.....	38
Preparation.....	38
APPENDIX A - AUXILIARY CABLE	39
APPENDIX B - CONTROL CABLE	40
APPENDIX C- CABLES BY TYPE	41
APPENDIX D - VRX1000 ANTENNAS	43
Glossary.....	44

Proprietary Statement

© 2024 Futurecom Systems Group, ULC
All Rights Reserved

Futurecom, PDR8000, DVR-LX, the Futurecom Logo and the Stylized FC logo are registered trademarks of Futurecom Systems Group, ULC. All other trademarks are the property of their respective owner.

No part of this document, or any software included with it, may be reproduced and distributed without the prior written permission of the copyright holder. Futurecom Systems Group ULC. reserves the right to make changes or improvements to the equipment, software or specification described in this document at any time and without prior notice. These changes will be incorporated in the new releases of this document.

This document may contain technical inaccuracies or typographical errors. Futurecom Systems Group, ULC. waives responsibility for any labour, materials or costs incurred by any party as a result of using this document. MOTOROLA, MOTO, MOTOROLA SOLUTIONS and the Stylized M Logo are trademarks or registered trademarks of Motorola Trademark Holdings, LLC and are used under license. All other trademarks are the property of their respective owners.

Commercial Warranty

Please reference Futurecom's Terms and Conditions of Sale, Section 7 regarding standard warranty (Futurecom Website > Terms and Conditions).

Declaration of Conformity

This equipment has been tested and found to comply with the limits for a Class B digital device, pursuant to Part 15 of the FCC Rules. These limits are designed to provide reasonable protection against harmful interference when the equipment is operated in a commercial environment. This equipment generates, uses, and can radiate radio frequency energy and, if not installed and used in accordance with the instruction manual, may cause harmful interference to radio communications. However, there is no guarantee that interference will not occur in a particular installation.

Changes or modifications not expressly approved by Futurecom Systems Group, ULC, could void the User's authority to operate the equipment.

Important Safety Information

The DVRS Repeater is intended for use in occupational / controlled conditions, where users have full knowledge of the operator exposure and can exercise control over the operator exposure to meet FCC/ISED limits. This radio is NOT authorized for general population, consumer, or any other use.

Notice to Users (FCC/ISED)

To satisfy FCC/ISED RF exposure requirements for mobile transmitting devices, refer to the RF Safety Booklet^[1] for TX – RX duty cycle and a separation distance between the antenna of this device and persons during operation. To ensure compliance, operations at closer than this distance is not allowed.

Futurecom requires the P25 DVRS operator to ensure FCC/ISED Requirements for Radio Frequency Exposure are met. The minimum distance between all possible personnel and the body of the DVRS equipped vehicle is specified in the RF Safety Booklet^[1]. Failure to observe the Maximum Permissible Exposure (MPE) distance exclusion area around the antenna may expose persons within this area to RF energy above the FCC exposure limit for bystanders (general population).

It is the responsibility of the repeater operator to ensure that MPR limits are observed at all times during repeater transmissions. The repeater operator must ensure at all times that no person comes within MPE distance from the antenna.

^[1] Refer to RF Safety Booklet available on the Futurecom website.
8M087X03 R1.1

Déclaration de Conformité

Cet équipement a été testé et déclaré conforme aux limites pour appareils numériques de classe B selon la partie 15 des règlements de la FCC. Ces limites sont destinées à assurer une protection raisonnable contre les interférences nuisibles dans une installation commerciale. L'équipement génère, utilise et peut émettre de l'énergie de fréquence radio et peut causer des interférences nuisibles aux communications radio s'il n'est pas installé ou utilisé conformément au mode d'emploi. Toutefois, rien ne garantit l'absence d'interférences dans une installation particulière.

Les changements et les modifications qui n'ont pas été approuvés expressément par Futurecom Systems Group ULC pourraient faire perdre à l'utilisateur son droit à utiliser cet équipement.

Informations de Sécurité Importantes

Le répéteur DVRS est conçu pour être utilisé dans des conditions professionnelles/contrôlées, dans lesquelles les utilisateurs connaissent à fond leur exposition et peuvent exercer le contrôle nécessaire sur celle-ci pour se conformer aux limites de la FCC/ISED. Cette radio N'EST PAS autorisée pour être utilisée par le grand public, les consommateurs ou autres.

Avis Aux Utilisateurs (FCC/ISED)

Pour satisfaire les exigences de la FCC/d'ISED en matière d'exposition à l'énergie RF pour les transmetteurs mobiles, prière de consulter la Brochure Sécurité RF¹ pour obtenir le facteur d'utilisation transmission/réception et la distance de séparation entre l'antenne de cet appareil et les personnes pendant l'utilisation. Pour assurer la conformité, le fonctionnement à une distance moins élevée n'est pas autorisé.

Futurecom demande à l'opérateur du répéteur P25 DVRS de satisfaire aux exigences de la FCC/ISED en matière d'exposition à l'énergie RF. La distance minimale entre toutes les personnes possibles et une antenne omnidirectionnelle doit respecter les indications de la Brochure Sécurité RF¹. Tout manquement à respecter la zone d'exclusion autour de l'antenne définie par la distance correspondant à la limite d'exposition maximale peut exposer les personnes qui se trouvent dans ce rayon à une énergie RF supérieure à la limite d'exposition de la FCC pour les spectateurs (population générale).

C'est à l'opérateur du répéteur qu'il incombe de s'assurer que les limites d'exposition maximales sont respectées en tout temps pendant les transmissions du répéteur. L'opérateur du répéteur doit s'assurer en tout temps que personne ne s'approche de l'antenne à une distance inférieure à celle correspondant à la limite d'exposition minimale.

¹ Prière de consulter la Brochure Sécurité RF sur le site Web de Futurecom.

Introduction

The Vehicular Repeater Extender (**VRX1000**) extends simplex communication to Portables from dispatch and from Portable radios to dispatch. (It's a Simplex radio extender in both inbound and outbound direction). When the VRX1000 is interfaced to a Motorola Mobile Subscriber Unit (**MSU**), the complete equipment package is referred to as Digital Vehicular Repeater System (**DVRS**).

When a Portable Subscriber Unit (**PSU**) has difficulty reaching a system tower, a VRX1000 can help by linking the PSU to a higher power mobile radio or MSU. The VRX1000 is designed to be seamlessly interfaced to:

- Remote Mount APX Series MSU with or without a Control Head (O2, O3, O5, O7, O9, or E5)
- For full list of compatible MSUs refer to compatibility chart at [Futurecom website](#) → [Support](#) → [Documentation and Software](#) → [VRX1000/Firmware/Firmware-Compatibility Chart](#)

NOTES:

- MSU must be configured as Remote Mount to be compatible with the VRX1000.
- APX 8500 MSU may require interface kit. Please refer to the VRX1000 Ordering Guide.
- The MSU configured for DVRS operation can support up to two control heads.
- All control and status of the VRX1000 are provided by the APX MSU control head. The control head is mounted in the front of the vehicle while the VRX1000 and associated filtering is housed in the back.

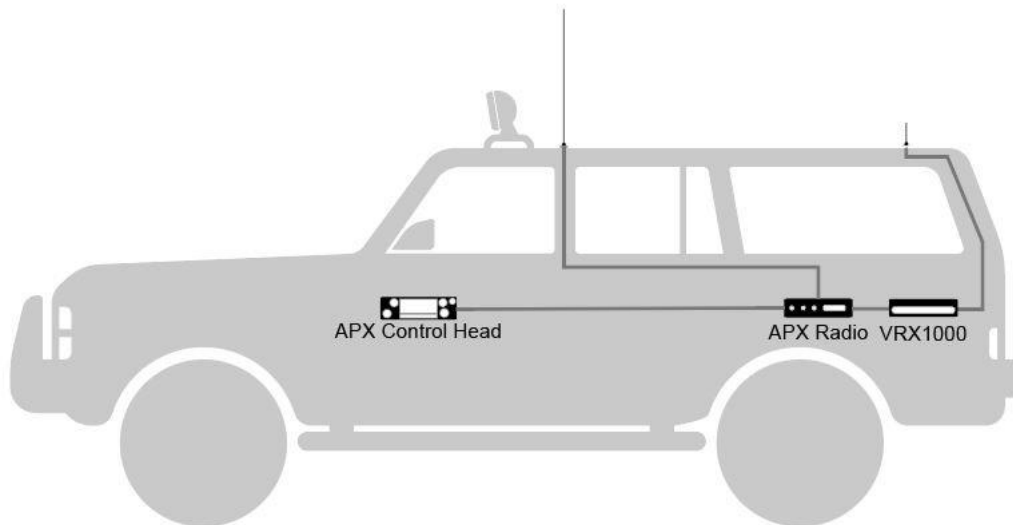

Figure 1: VRX1000 Equipment in Vehicle Layout

Installation Planning



Cautionary Notes & Considerations



FILTER LIMITS: The VRX1000 for In-Band operation is shipped equipped with custom filters tuned to the specified frequency range provided by the customer. Programming the VRX1000 / MSU to operate on frequencies outside of the original specified bands may result in intermittent or complete loss of communications. Frequency changes may require filter retuning or replacement.

TRANSMIT POWER (CROSS-BAND): The cross-band VRX1000 can be interfaced to a high power MSU, however, the transmit power of the MSU must be reduced to comply with the maximum power restrictions described in the DVRS RF Safety Booklet².

TRANSMIT POWER (IN-BAND): In all in-band DVRS configurations, the MSU transmit power must not exceed 50 Watts on DVRS Enabled MSU Modes due to the in-band filters' power rating. The in-band filters connected to the MSU have typical insertion loss of 1.5dB.

Tools Required

Description	Needed For
Drill	Installer preferred mounting hardware
Center Punch (Optional)	Installer preferred mounting hardware
4mm Allen Key	6mm shoulder screws for securing VRX1000 flat mount to its mounting base
Wire Cutters and Crimping Tool	DC power cable installation
3/16" Flat Screwdriver	Cable connector screws

² Refer to RF Safety Booklet available on the Futurecom website.
8M087X03 R1.1

Programming Details

This section will detail programming information needed to enable certain installation options. For full instructions on how to program the VRX1000, please refer to the VR Programming Guide³.

Bypass Switch

RF Bypass Switch with non-APX 8500 MSU

If installing an in-band VRX1000, it comes equipped with an internal RF bypass switch.

- required for all In-band applications
- bypasses the MSU filter when an In-Band VRX1000 Disabled channel is selected

When the VRX1000 is paired with a non-APX 8500 MSU, the switch bypasses the filtering at the output of the MSU when a VRX1000 disabled talk group (TG) is selected on the MSU control head.

MSU RF By Pass Switch Extension

- required for in-band application for APX8500 w All Band antenna
- Bypasses the MSU filter when a cross band channel is selected

To enable the RF bypass switch operation, the following must be configured via Futurecom Repeater Configurator (FRC) in the Hardware Setup menu (Figure 2):

- **MSU RF Bypass Switch** = checked (enabled)
- **Relay Use- Relay 1** = MSU RF Bypass Sw.

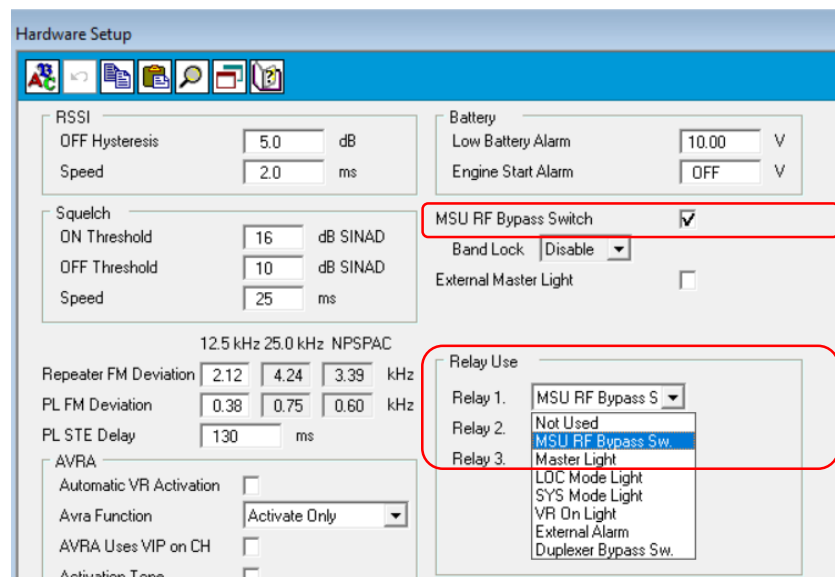

Figure 2: RF Bypass Switch Configuration

³ Refer to VR Programming Guide available on the Futurecom website.
8M087X03 R1.1

RF Bypass Switch with APX 8500 MSU with Triplexer and Single Band Antennas

If installing an in-band VRX1000, it comes equipped with an internal RF bypass switch. This switch bypasses the filtering at the output of the MSU as required to allow access to the full frequency band when VRX1000 is not enabled or to block certain frequencies when VRX1000 is active to ensure interference-free communication.

When the VRX1000 is paired with an APX 8500 MSU using a triplexer and single band antennas, the switch bypasses the filtering at the output of the MSU when a VRX1000 disabled talk group (TG) is selected on the MSU control head.

To enable the RF bypass switch operation, the following must be configured via FRC in the Hardware Setup menu (**Figure 2**):

- **MSU RF Bypass Switch** = checked (enabled)
- **Relay Use- Relay 1** = MSU RF Bypass Sw.

RF Bypass Switch with APX 8500 MSU and All Band Antenna

If installing an in-band VRX1000, it comes equipped with an internal RF bypass switch. This switch bypasses the filtering at the output of the MSU as required to allow access to the full frequency band when VRX1000 is not enabled or to block certain frequencies when VRX1000 is active to ensure interference-free communication.

When the VRX1000 is paired with an APX 8500 MSU connected an all-band antenna, this switch bypasses the filtering at the output of the MSU as needed.

MSU in-band filter is in use when:

- MSU is on an in-band channel/TG AND VRX1000 is enabled

MSU in-band filter is not in use when:

- MSU is on a cross-band channel/TG OR
- MSU is on an in-band channel/TG AND VRX1000 is disabled

To enable the correct RF Switch operation, the following must be configured via FRC:

- **Hardware Setup**→ **MSU RF Bypass Switch** = checked (enabled) (See: **Figure 2: RF Bypass Switch Configuration**)
- **Hardware Setup**→ **Relay Use**→ **Relay 1** = MSU RF Bypass Sw. (See: **Figure 2: RF Bypass Switch Configuration**)
- **VR Common Setup**→ **MSU RF Bypass Switch Extension (APX 8500 and All Band Antenna)**= checked (enabled) (See: **Figure 3: RF Bypass Switch Extension Configuration**)

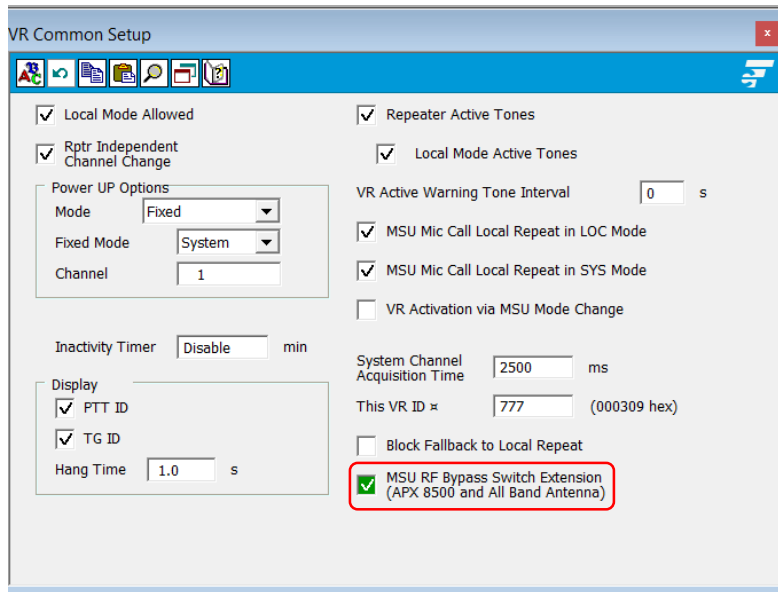

Figure 3: RF Bypass Switch Extension Configuration

NOTE: For in-band configurations where an APX 8500 interface kit is also required, the above programming is still required. Instructions on how to install an interface kit with an in-band DVRS are provided separately from this manual⁴.

⁴ Contact Futurecom to determine if an interface kit is required or to obtain an installation drawing.
8M087X03 R1.1

Status Lights

The relay outputs on the VRX1000 can be programmed to provide several status indications – ‘Primary Light’, ‘VR On Light’, ‘LOC Mode Light’, or ‘SYS Mode Light’.

Primary & On Lights

The VRX1000 status icon located on the top right corner of the control head can be used to determine when the repeater is on and whether it is acting as a Primary or Secondary device. Due to the limited space on the control head, the icon is quite small, and some users may prefer to have a more obvious light indication of the VRX1000 status.



Figure 4: Control Head Display--Status Icon

A pair of lights may be connected to the AUX port with the light colour used to indicate whether the VRX1000 is on (Secondary mode), and when it is in Primary mode.

For example, if a red light is connected to Relay 2 and a yellow light is connected to Relay 3, the following light combinations will be seen:

Primary VRX1000 – Red and Yellow lights

Secondary VRX1000 – Yellow light only

To enable the lights operation, the following must be configured via FRC in the Hardware Setup menu:

- **External Master Light** = checked (enabled)
- **Relay Use** → **Relay 2** = Master Light
- **Relay Use** → **Relay 3** = VR On Light

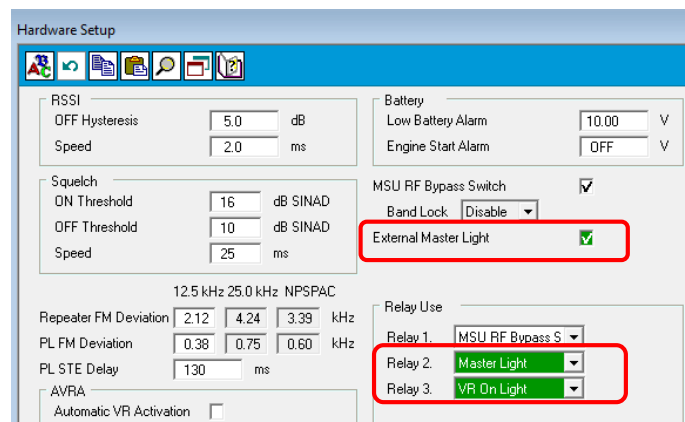

Figure 5: Primary & Lights On Configuration

System & Local Mode Lights

The top line of the control head can be used to determine whether the VRX1000 is operating in system (SYS) or local (LOC) mode. Some users may prefer to have a more obvious indication of the VRX1000 status.

NOTE: VRX1000 does not support Local Repeat however, the Mic PTT will be transmitted to the local portables in Local Mode.



Figure 6: Control Head Display--System/Local

A pair of lights may be connected to the AUX port with the light colour used to indicate whether the VRX1000 is in System or Local mode.

To enable the lights operation, the following must be configured via FRC in the Hardware Setup menu:

- **Relay Use** → **Relay 2** = SYS Mode Light
- **Relay Use** → **Relay 3** = LOC Mode Light

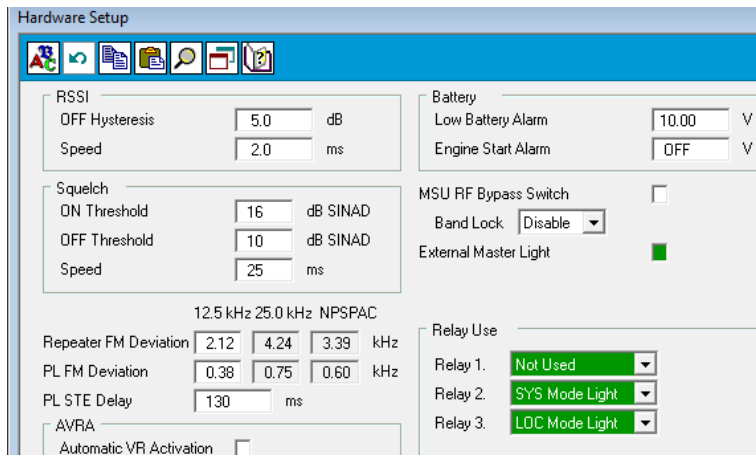

Figure 7: System and Local Mode Lights Configuration

Automated VR Activation (AVRA) and Primary/Secondary Preference Trigger

This input is used to trigger AVRA and/or Primary/Secondary Preference.

The AVRA option enables automated VRX1000 ON/OFF control triggered by an external switch – portable charger, door switch etc.

Refer to the programming instructions for Automated VR Activation (AVRA) to enable this functionality.

To enable AVRA operation, the following must be configured via FRC in the Hardware Setup menu:

Option 1: A dedicated VIP Input on the MSU Control Head or DEK⁵.

- **Automatic VR Activation** = checked
 - **Use VIP on Ctl Head** = checked
- NOTE: Input Polarity will be greyed out and corresponding VIP I/P must be enabled in the MSU⁶.

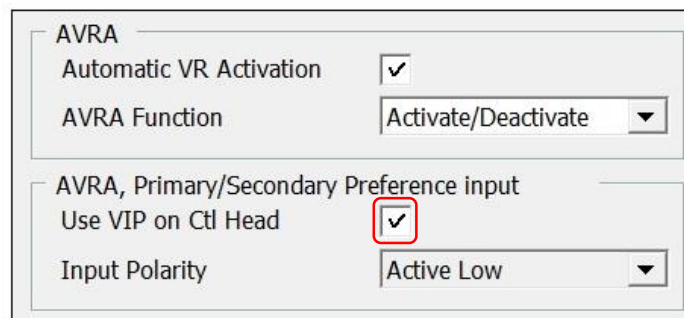

The screenshot shows a configuration window with two sections. The top section is titled 'AVRA' and contains 'Automatic VR Activation' with a checked checkbox and 'AVRA Function' with a dropdown menu set to 'Activate/Deactivate'. The bottom section is titled 'AVRA, Primary/Secondary Preference input' and contains 'Use VIP on Ctl Head' with a checked checkbox (highlighted by a red square) and 'Input Polarity' with a dropdown menu set to 'Active Low'.

Figure 8: AVRA VIP Configuration

Option 2: 'Switch 1 Input' on the DB15 of the VRX1000 Y Control with Aux Cable.

Note: With an in-band configuration, the VRX1000 Y Control with Aux cable is provided. For a cross-band configuration, the cable will need to be ordered separately- order number: VKN0011A (3ft).

- **Automatic VR Activation** = checked
 - **Use VIP on Ctl Head** = unchecked
- NOTE: The MSU does not require special programming related to the enabling of this option.
- The **Input Polarity** field is only applicable if the "**Use VIP on Ctl Head**" field is unchecked.
 - If Input Polarity is set to Active High, leaving Pin 1 on the Auxiliary Cable disconnected is Active, and grounding Pin 1 is Inactive.

⁵ For detailed instructions on VIP wiring, please refer to the MSU installation manuals available from Motorola.

⁶ Refer to programming guide provided by Motorola for detailed instructions.

- If Input Polarity is set to Active Low, grounding Pin 1 on the Auxiliary Cable is Active, and leaving Pin 1 disconnected is Inactive.

AVRA

Automatic VR Activation

AVRA Function Activate/Deactivate

AVRA, Primary/Secondary Preference input

Use VIP on Ctl Head

Input Polarity Active Low

Figure 9: AVRA Auxiliary Configuration

Monitoring Setup

Transmitter Mode Tx-Enable

TX ON

PTT PTT OFF

Repeater CAS Idle

RSSI Idle

SqL Idle

RF Power OFF dBm

0.00 W

Test Mode NO

Oper. State OFF

Ant. Sw. BL-REVERSE

RSSI -123.1 dBm

0.16 μ V

Mobile RUS Idle

Mobile PTT ---

Temp 32 $^{\circ}$ C

PA_t 30 $^{\circ}$ C

P25 Rx Modem Test

Test Mode NO

BER 0.00 %

BERm 0.00 %

PL ---

SINAD --- dB

AVRA/Motion Input Inactive/Motion

Figure 10: Monitoring Setup Window

This field is useful for testing installation to ensure that the input has been connected, and configured to the correct polarity. The state of the input is updated as the VRX1000 or VIP input signal changes.

Mounting Instructions



Cautionary Notes & Considerations



ACCESSIBILITY: When planning the DVRS installation, make sure to leave adequate room around all DVRS modules to allow for easy RF and control cabling connections, to enable programming / re-flashing access to both the VRX1000 and MSU ports and access to the VRX1000 mounting screws.

CABLE RANGE: Ensure all DVRS components, including the remote mount MSU, are mounted within the interconnecting cables range.

CONTROL HEAD: Ensure control head is installed in front of the vehicle.

MSU AND ACCESSORIES: For detailed MSU and accessories installation instructions, please refer to the installation manuals available from Motorola.

Preparation

The VRX1000 is shipped with a mounting base attached by 8 screws. If a template is needed for installation, the mounting base may be removed and used for that purpose. (See **Figure 11: VRX1000 Mounting Screws**)

Instructions

Step 1: Secure VRX1000 to mounting surface with 4 fasteners. (recommend 6mm or 1/4")

NOTE: There are holes to accommodate up to 8 mounting points, with only 4 required (See **Figure 11: VRX1000 Mounting Screws**)

Step 2: Secure in-band VRX Filter and MSU Filter each with 4 fasteners (if applicable)

Step 3: Connect all cables according to appropriate configuration.

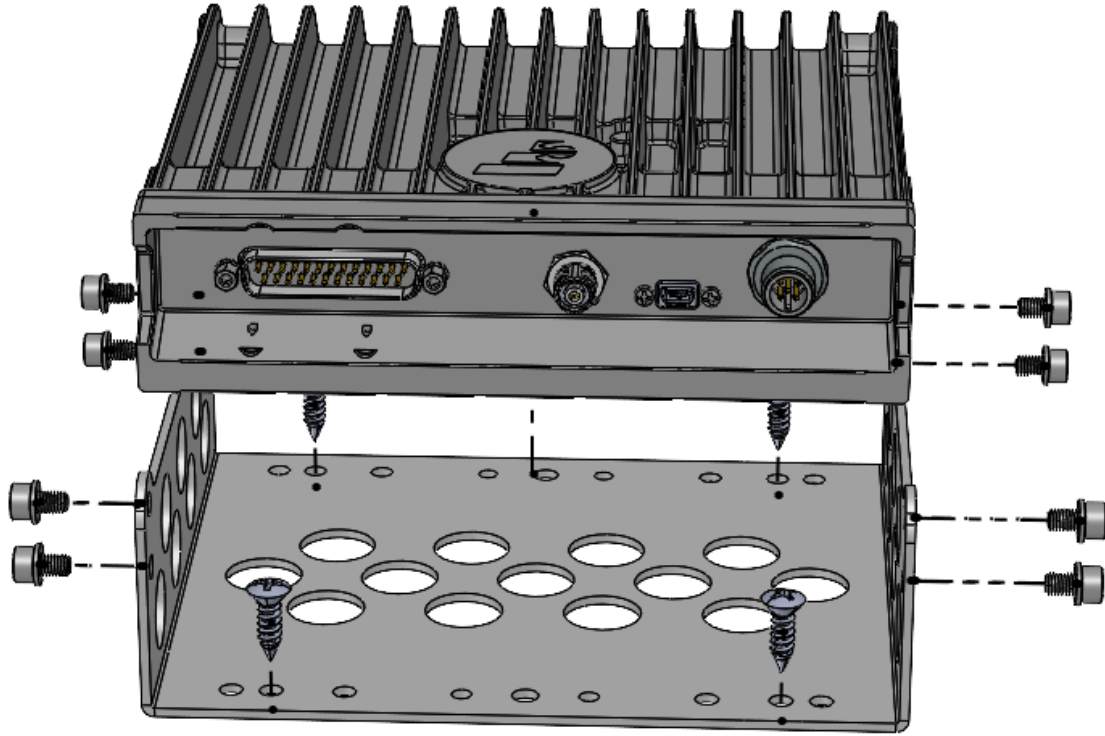

Figure 11: VRX1000 Mounting Screws

Cable Connections



Cautionary Notes & Considerations



CABLE LENGTHS: Unless special cabling length is specified upon placing an order, the VRX1000 is shipped with a standard 3ft-long interconnect cable between the MSU and VRX1000.

GROUND POLARITY: The VR operates only in negative ground, +12VDC electrical systems. Before starting the installation, make sure that the ground polarity of the vehicle is correct. Accidentally reversing the polarity will not damage the VR but will cause the cable fuse to blow. Futurecom recommends installation of voltage surge protection to protect the car electronics to prevent spikes in the supply voltage. (fuse is 7A, 0.25"x1.25", fast-acting fuse)

VEHICLE USER MANUAL: Before installing any electrical equipment, check the vehicle manufacturer's User Manual.

Configuration Terms:

In-Band: VRX1000 operates in the same frequency band as a system frequency band.

Cross-Band: VRX1000 operates in a different frequency band than all the system frequency bands.

Flat: VRX1000 components are provided individually allowing for a lower profile installation.

VRX1000 Connections

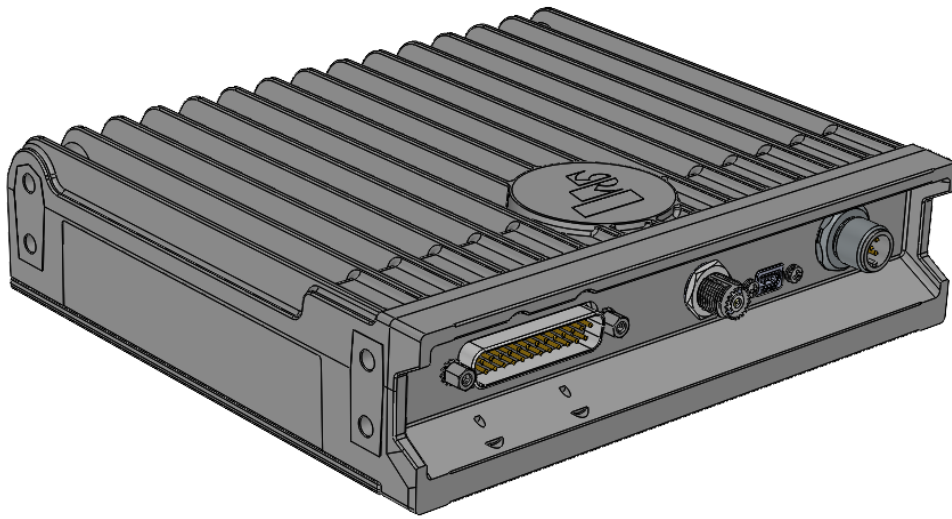

Figure 12: VRX1000



Figure 13: VRX1000--Front View

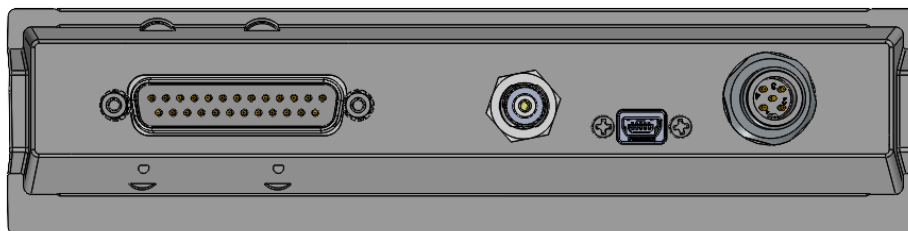

Figure 14: VRX1000--Back View

The front of the VRX1000 has a green LED that indicates the unit is powered on.

The back of the VRX1000 includes connections for:

- MOBILE RADIO- for connection to the mobile radio or optional Y- cable with AUX connection
- Antenna port for the VRX1000 antenna

- USB- for programming cable
- POWER- for connecting to vehicle battery

In-Band VRX Filter, MSU Filter and RF Bypass Switch Connectors

For In-Band VRX1000 configurations, two notch filters and a RF Bypass switch are also required. Typically, the VRX1000 notch filter, the MSU notch filter, and the RF bypass switch are flat mounted, as shown in Figure 15 and Figure 17 . Each filter is connected between the VRX1000/MSU and its antenna.

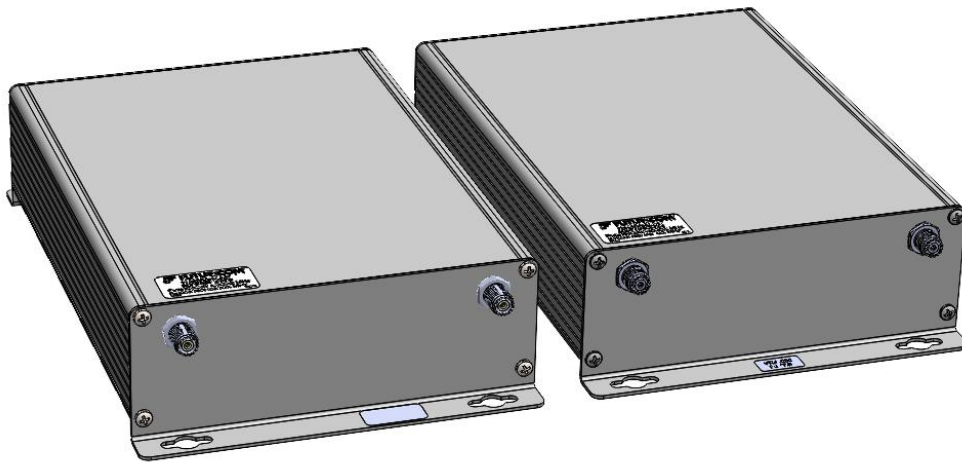

Figure 15: In-Band VRX1000 and MSU Filters for 700/800, UHF and VHF

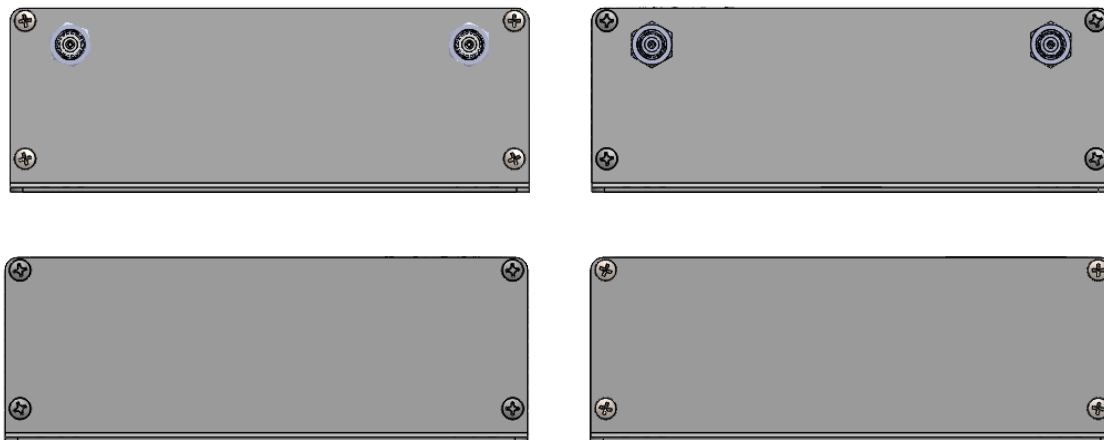

Figure 16 : VRX and MSU Filter Connectors for 700/800, UHF and VHF--Front and Back View

The back of the VRX1000 notch filter includes connections for:

- TO VRX1000 ANTENNA- Mini UHF Female connector connection to VRX1000 antenna
- TO VRX1000 - Mini UHF Female connector for the antenna port on the back of the VRX1000

The back of the MSU notch filter includes connections for:

- TO RF SWITCH (2- Mini UHF female connector)

The front of the VRX1000 notch filter and MSU notch filter have no connection options.

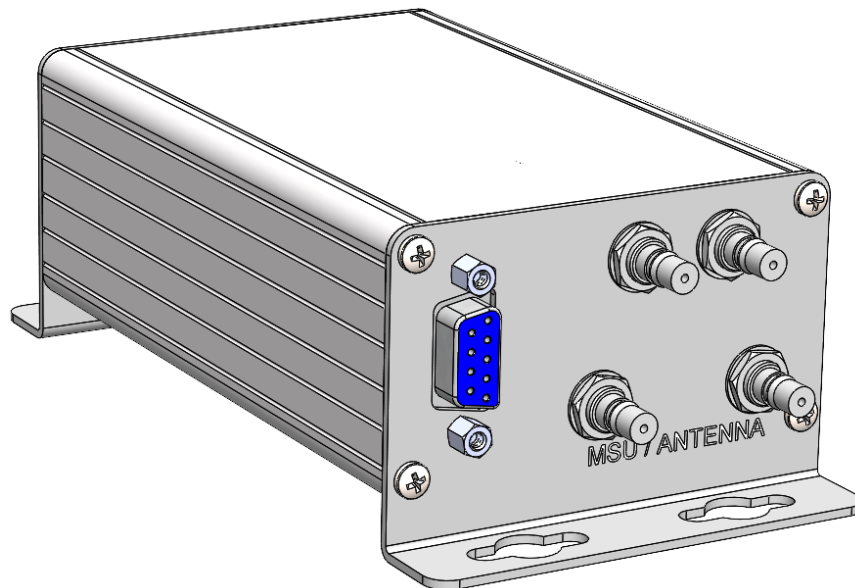

Figure 17: RF Bypass Switch

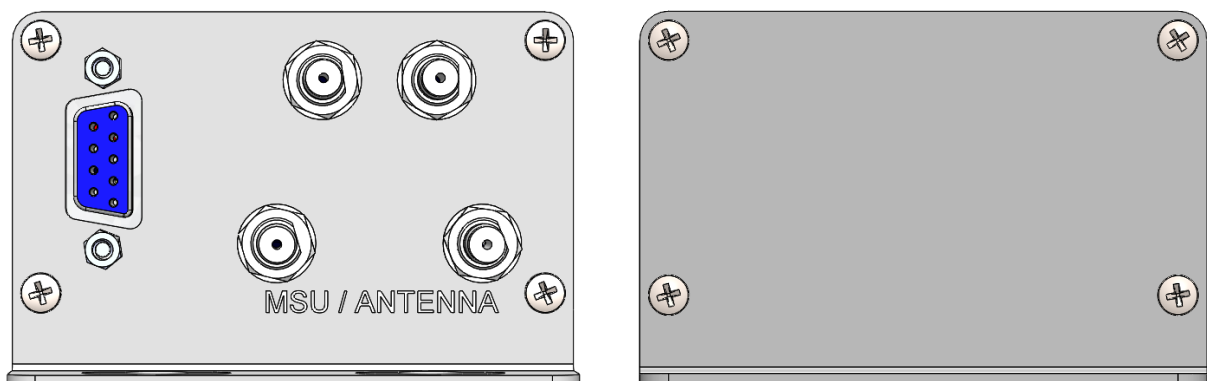

Figure 18: RF Bypass Switch—Front and Back View

The back of the RF bypass switch includes connections for:

- TO RF BYPASS SWITCH – DB9 Female Connector to Relay Switch
- TO MSU FILTER (2) – QMA Female connector to MSU notch filter
- TO MOBILE ANTENNA- QMA Female connector to MSU antenna
- TO MOBILE RADIO- QMA Female connection to antenna port at the back of the MSU

The front of the RF bypass switch has no connection options.

Power Cable

The following steps detail how to run the power cable from the vehicle battery to the mounting location for the VRX1000.

1. Determine power cable routing between the VRX1000 mounting location and the vehicle battery.
2. Locate an existing hole with a grommet in the vehicle firewall. If a firewall hole does not exist, drill an access hole in the firewall for cable passage. Install a grommet in the hole to avoid damage to the power cable.
3. From the inside of the vehicle, feed the red lead (without lug attached) through the access hole into the engine compartment.
4. Find a grounding point close to the VRX1000 location. Shorten the black lead.
5. Strip the end of the black lead as required. Crimp the large lug on the black lead and connect it to the vehicle chassis ground.
6. Trim the red lead to the proper length. Strip the end of the red lead as required. Crimp the large lug on the red lead.
7. Locate the fuse holder as close to the battery as possible and away from hot engine parts. Cut the red lead at this location. See detailed fuse holder installation steps below.
8. Connect the red lead lug to the battery positive (+) terminal.

HFB Fuse Holder Installation:

HFB Fuse Holder is a model of in-line waterproof fuse holders.

1. Lubricate ends of both wires with isopropyl alcohol or WD-40 and push one wire into each half of the fuse holder.
2. Strip 0.25" (6.3mm) of insulation from ends of both wires. Make sure that no more than 0.25" (6.3mm) of insulation is stripped.
3. Insert stripped wire into the contact clip and crimp it (2 places).
4. Recommended crimping tools:
 - a. Thomas & Betts – ERG4002
 - b. Channellock No. 909
 - c. Thomas & Betts WT-112M
5. Verify that bare wires do not extend past the crimping sleeve.
6. Seat contact clips into the fuse holder with a 0.25" (6.3mm) wood dowel.
7. Insert the fuse into one end of the fuse holder and fully close the fuse holder.
8. Loop the wires as shown in **Figure 19: HFB Fuse Holder Installation** and secure both wires together with a cable tie as shown.

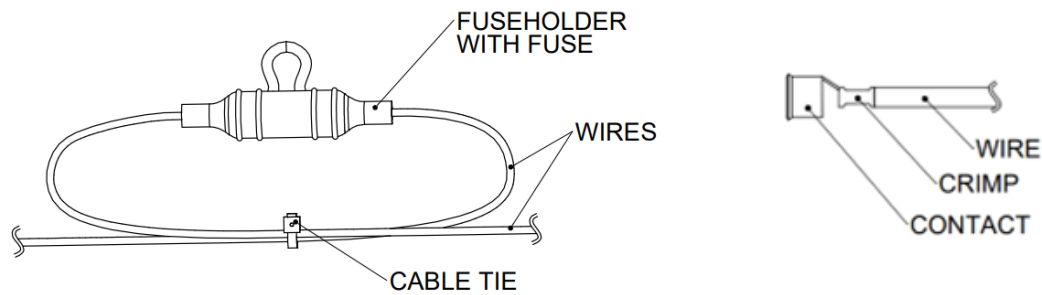

Figure 19: HFB Fuse Holder Installation

HHB Fuse Holder Installation:

HHB Fuse Holder is a model of in-line waterproof fuse holders.

1. Strip insulation from wire (approximately 10mm [3/8"]).
2. Insert wire into holder.
3. Crimp terminal through body. The recommended crimp pressure range is 160 MPa ~ 210 MPa, the preferred pressure is 180 MP. See **Figure 20: HHB Fuse Holder Installation**
4. Recommended Crimping Tools:
 - a. Thomas & Betts - ERG-2001
 - b. Channellock No. 909
 - c. General Electric – U.S. & Metric Electrical Terminal Tool
5. Repeat steps 1-3 for other half of the holder. See **Figure 20: HHB Fuse Holder Installation**
6. Insert fuse.
7. Snap housing together.
8. Loop the wires and secure both wires together with a cable tie as shown in **Figure 21: HHB Fuse Holder Assembly**.

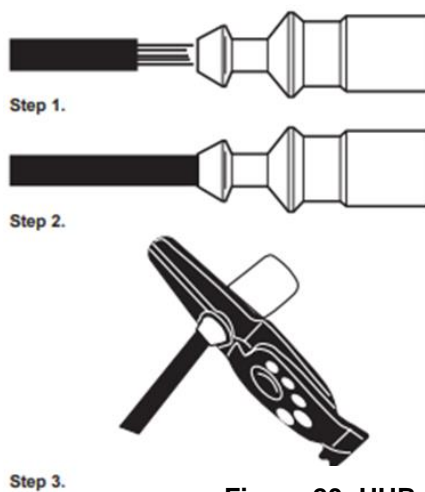

Figure 20: HHB Fuse Holder Installation

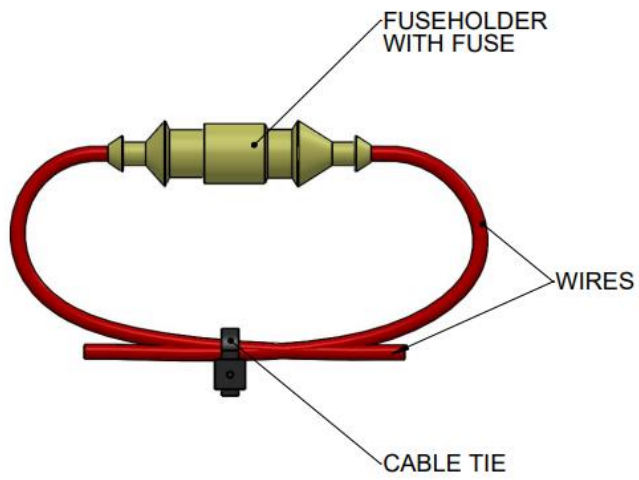

Figure 21: HHB Fuse Holder Assembly

Configuration Identification

Using the table below, identify which configuration of VRX1000 is to be installed and refer to the appropriate configuration drawing for cabling instructions.

VRX1000 Band	In-band/Cross-band w System Freq	Configuration #
VHF UHF 700MHz/800MHz (Non-APX 8500 MSU)	Cross-band	1
	In-band	2
VHF UHF 700MHz/800MHz (APX 8500 MSU)	Cross-band	3
	In-band	4

Standard Installation Cables

The following table outlines all of the cables that are needed for installation. It identifies the cable part number, length, connector types, and a description of what the cable connects together. All cables are provided at time of order except the auxiliary cable with cross-band configurations. The ordering code is provided for this optional cable, if needed. There is also a reference number for each cable that is used throughout the configuration drawings.

Ref #	PN	Length	Connectors	Description
1	7W087X07-01	3ft	DB25 Female to DB25 Male	VRX1000 to MSU Control Cable NOTE: Custom lengths available – up to 25ft.
2	7W087X08-01 OR 1W087B05-01	3ft	DB25 Female to DB25 with DB15 Female	VRX1000 to MSU 'Y' Control Cable with Auxiliary Option NOTE: Custom lengths available – up to 25ft.
3	7W087X20-01	18ft		VRX1000 Power Cable
4a	7W087X11-01	20"	RA Mini UHF Male to RA Mini UHF Male	VRX1000 to In-Band Filtering RF Cable
4b	7W900X94-01	20"	RA QMA to RA Mini UHF	MSU to In-Band Filtering RF Cable NOTE: For In-Band with Non APX 8500
4c	7W900X97-08	12"	RA QMA Male to RA QMA Male	MSU to In-Band Filtering RF Cable NOTE: For In-Band with APX 8500
5	7W083X09-01	1ft	15-Pin Male to 9-Pin Female	RF Switch Cable NOTE: For In-Band
6	Control Head cable provided by Motorola			
7	Y Cable provided by Motorola			

Installation Drawings

Configuration 1: VRX (700/800MHz, VHF or UHF) Cross-band Flat Mounted

Refer to [Standard Installation Cables](#) section for mapping of cable diagram numbers to part numbers.

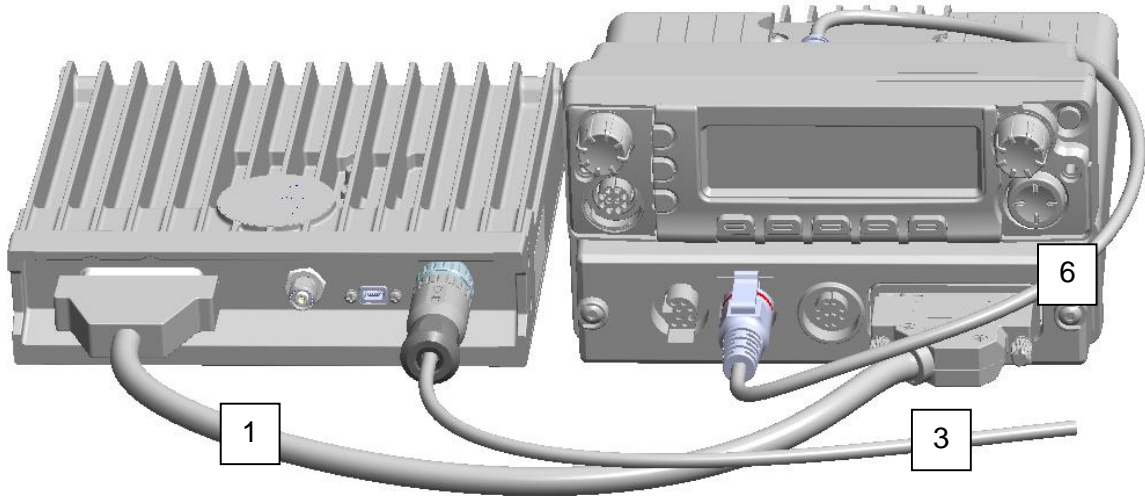

Figure 22: Configuration 1--Back View

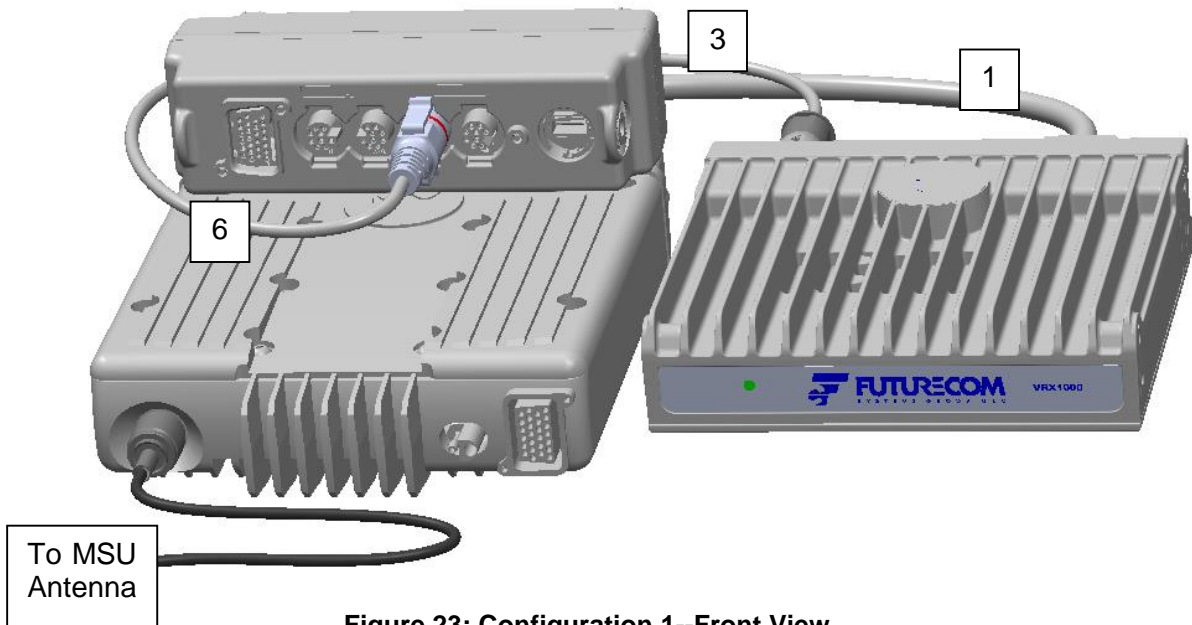

Figure 23: Configuration 1--Front View

In-Band RF Switching Cabling

To use the RF Bypass Switch for In-Band VRX1000 units, connect cables 2 and 5 as shown in **Figure 24**. To enable the RF Switch operation, refer to the programming instructions for the **Bypass Switch**.

Configuration 2: VRX (700/800MHz, VHF or UHF) In-band Flat Mounted (Non-APX 8500 MSU)

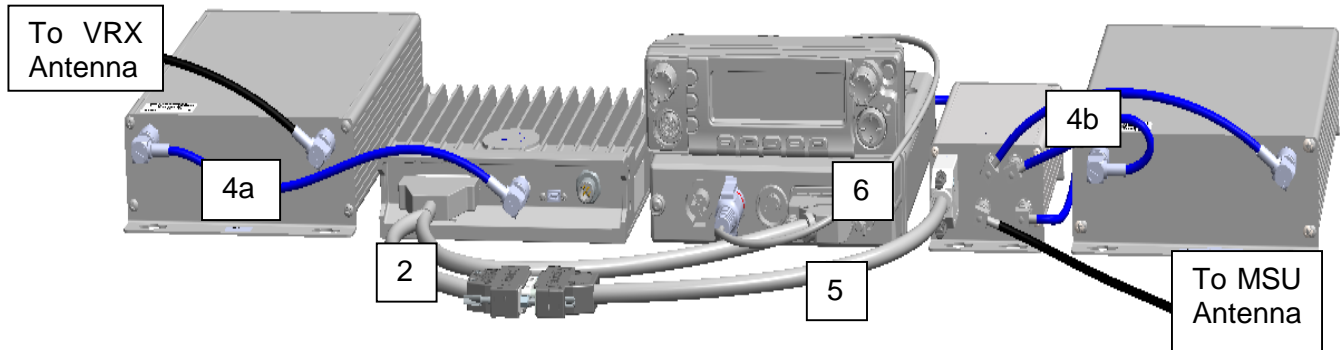

Figure 24: Configuration 2--Back View

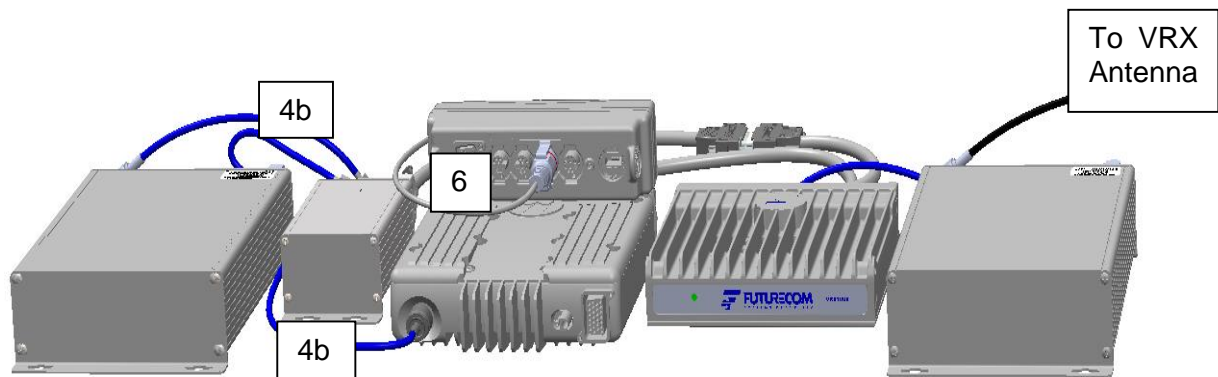

Figure 25: Configuration 2--Front View

Configuration 3: VRX (700/800MHz, VHF or UHF) Cross-band Flat Mounted (APX8500 MSU)

Note: VRX1000 Cross-Band operation with APX 8500 MSU requires at least 40dB VR-to-APX Antenna Isolation. Contact Futurecom Sales or visit our website for the Interface Selection Kit for APX8500 to determine if an interface kit is required or to obtain an installation drawing.

Configuration 4: VRX (700/800MHz, VHF or UHF) In-band Flat Mounted (APX8500 MSU)

Figure 26 shows the RF connections only and

Figure 27 shows the connection between the MSU, VRX1000 and the RF Switch and does not include the MSU's control head and cable.

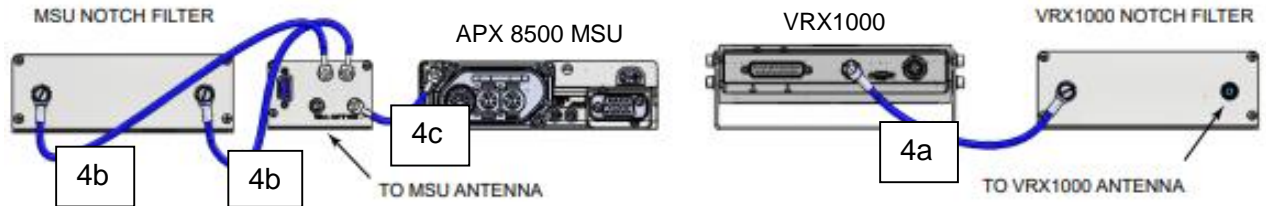

Figure 26: Configuration 4--Back View (Connection Cables for Filters, RF Switch and Antenna Ports)

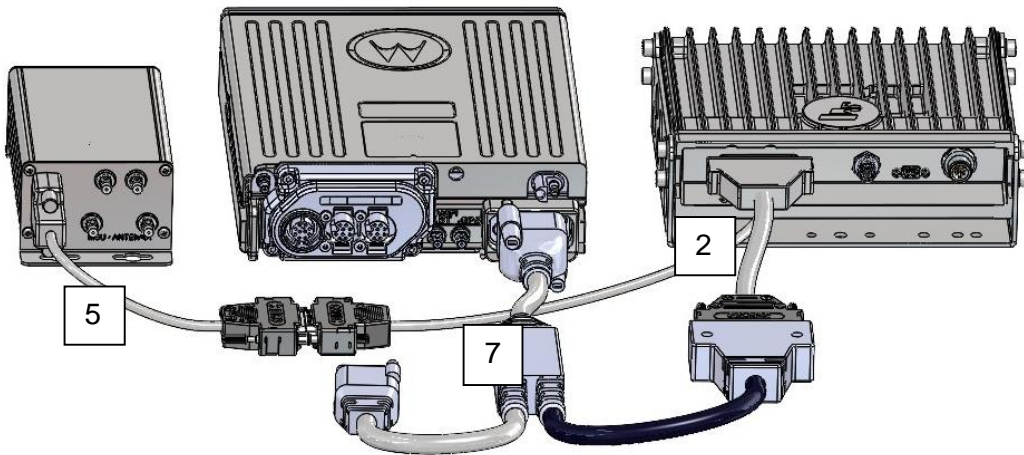

Figure 27: Configuration 4--Back View (Connection between MSU, VRX and RF Switch)

Auxiliary Port Options

The VRX1000 Auxiliary port is provided on the MSU Y-Control Cable Aux (Part Number 7W087X08-01 OR 1W087B05-01). It provides three relay driver output ports and two switch contact input ports, which can be interfaced to external logic. The external logic can be easily interfaced by connecting to the correct pins on the DB15 connector of the auxiliary cable (Ref# 2, Part Number 7W083X09-01). The cable pinout details are captured in [APPENDIX A](#).

In-Band Auxiliary Cabling

For all In-Band configurations, the RF Switch is controlled from the auxiliary port. Installation instructions are provided in the configuration diagrams. Refer to the programming instructions for the Bypass Switch.

To connect additional external logic, the DB15 male connector of the RF switch cable (Ref# 7, Part Number 7W083X09-01) can be opened, and extra wires added to the corresponding pins as described in [APPENDIX A](#).

Possible applications for the auxiliary port include Status Lights and AVRA.

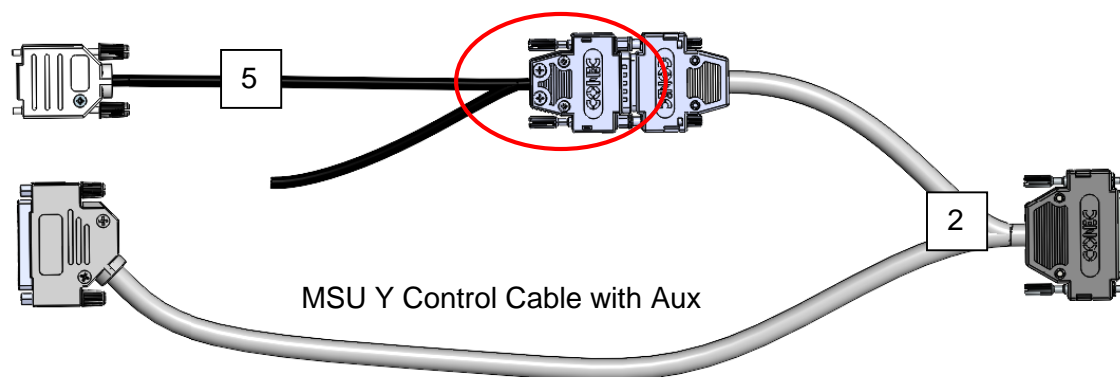

Figure 28: Customizing RF Switch Cable

Cross-Band Auxiliary Cabling

To connect a required external logic option cable (provided 3rd party availability), terminate the cable with a DB15 male connector with the required pin out and connect it to the DB15 female connector of the Auxiliary cable. Refer to [APPENDIX A](#) for pinout details.

Possible applications for the auxiliary port include Status Lights and AVRA.

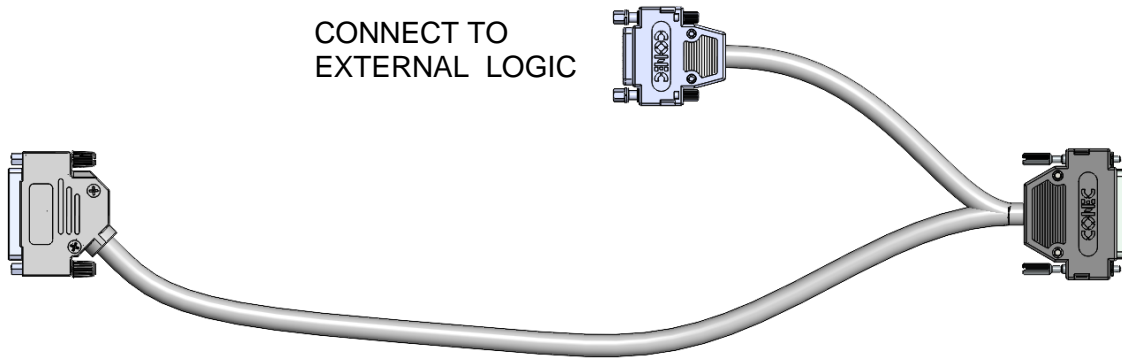

Figure 29: Auxiliary Cable Alternate Connections

Status Lights

The relay outputs in the VRX1000 can be programmed to provide several status indications – ‘Primary Light’, ‘VR On Light’, ‘LOC Mode Light’, or ‘SYS Mode Light’. The VRX1000 then provides control input to an external switch which in turn toggles an external light. The external switch and light are not included with the VRX1000.

The light switch relay coil “+” must be wired to +12V DC and the “-“ to the corresponding relay output on the DB15 connector of the MSU Y-Control cable with auxiliary port cable (500mA Max).

Refer to the programming instructions for **Status Lights** to enable this functionality.

Antenna Installation



Cautionary Notes & Considerations



ANTENNA ISOLATION (IN-BAND): All DVRS models require 30dB minimum antenna isolation between the VRX1000 and MSU Antennas in order to ensure interference-free operation. It is recommended that the MSU in-band antenna is mounted on the roof top of the vehicle while the VRX1000 antenna is mounted on the trunk.

ANTENNA PORTS: VRX1000 antenna port is 50 Ohm mini UHF female and require antenna with matching 50 Ohm mini UHF male terminations.

ANTENNA SEPARATION: Before starting the installation, inspect the vehicle and determine how and where to mount the DVRS antennas (one or two connected to the Mobile Radio and one to the VRX1000), the VRX1000 components, MSU, Control Head, MSU accessories. Ensure adequate separation between the MSU antennas and the VRX1000 antenna, especially in in-band configurations.

RF ENERGY SAFETY: To ensure optimum performance and compliance with RF energy safety standards, antenna installation guidelines are limited to metal-body vehicles with appropriate ground planes and consider the potential exposure of back seat passengers and bystanders outside the vehicle.

Preparation

Any DVRS model requires the use of two or three antennas – one or two connected to the MSU and one connected to the VRX1000. For a list of approved VRX1000 antennas, please refer to APPENDIX D - VRX1000 ANTENNAS.

The MSU and VRX1000 antennas must be installed in such a way as not to cause interference. If an APX 8500 installation kit is required to achieve this, please refer to separate installation instructions provided by Futurecom (8J087X51).

Before installing an antenna on the trunk lid:

- Ensure the distance from the antenna to the front surface of the rear back seat is greater than the minimum distance specified in the DVRS RF Safety Booklet⁷ for the specific DVRS model and frequency band.
- Ensure the trunk lid is grounded by connecting grounding straps between the trunk lid and the vehicle chassis.

To ensure compliance with RF energy safety standards, the antenna locations, gain and maximum transmit power (for both the MSU and the VRX1000) must be as specified in the DVRS RF Safety Booklet⁸.

⁷ Refer to RF Safety Booklet located on the Futurecom Website

⁸ Refer to RF Safety Booklet located on the Futurecom Website

APPENDIX A - AUXILIARY CABLE

VRX1000 Y Control with Auxiliary Cable (7W087X08-01 OR 1W087B05-01)

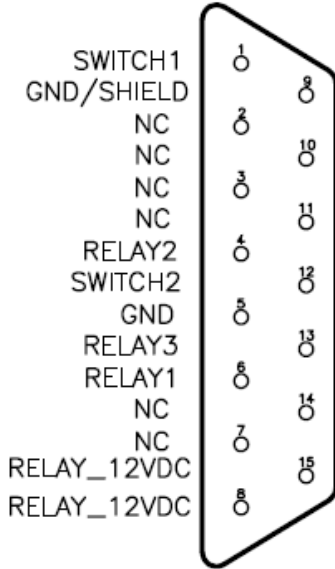

Pin #	Designation	Note
1	SWITCH 1	AVRA Input and/or the Primary/Secondary Preference Trigger, operating as programmed in the Futurecom Repeater Configurator's Hardware Setup Screen
2	NC	NOT USED
3	NC	NOT USED
4	RELAY 2	Primary Light Output / as programmed
5	GND	Ground
6	RELAY 1	RF Switch Output / as programmed
7	NC	NOT USED
8	RELAY_12VDC	12VDC for powering up relay coil. Max current draw is 750mA TOTAL from both pins 8 & 15.
9	GND/SHIELD	Ground / Shield
10	NOT USED	NOT USED
11	NC	NOT USED
12	SWITCH 2	For future use
13	RELAY 3	As programmed
14	NC	NOT USED
15	RELAY_12VDC	12VDC for powering up relay coil. Max current draw is 750mA TOTAL from both pins 8 & 15.

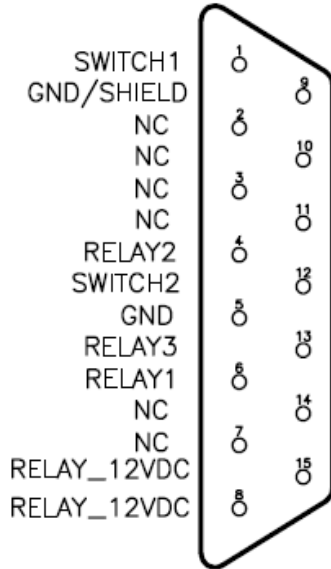

DB 15 (FEMALE)
TO EXTERNAL LOGIC CABLE
(PROVIDED BY CUSTOMER)

DB 25 (FEMALE)
TO VRX1000 PORT

Note: Pinout shown is front view

APPENDIX B - CONTROL CABLE

VRX1000 to MSU Y Control Cable (7W087X08-01 OR 1W087B05-01)

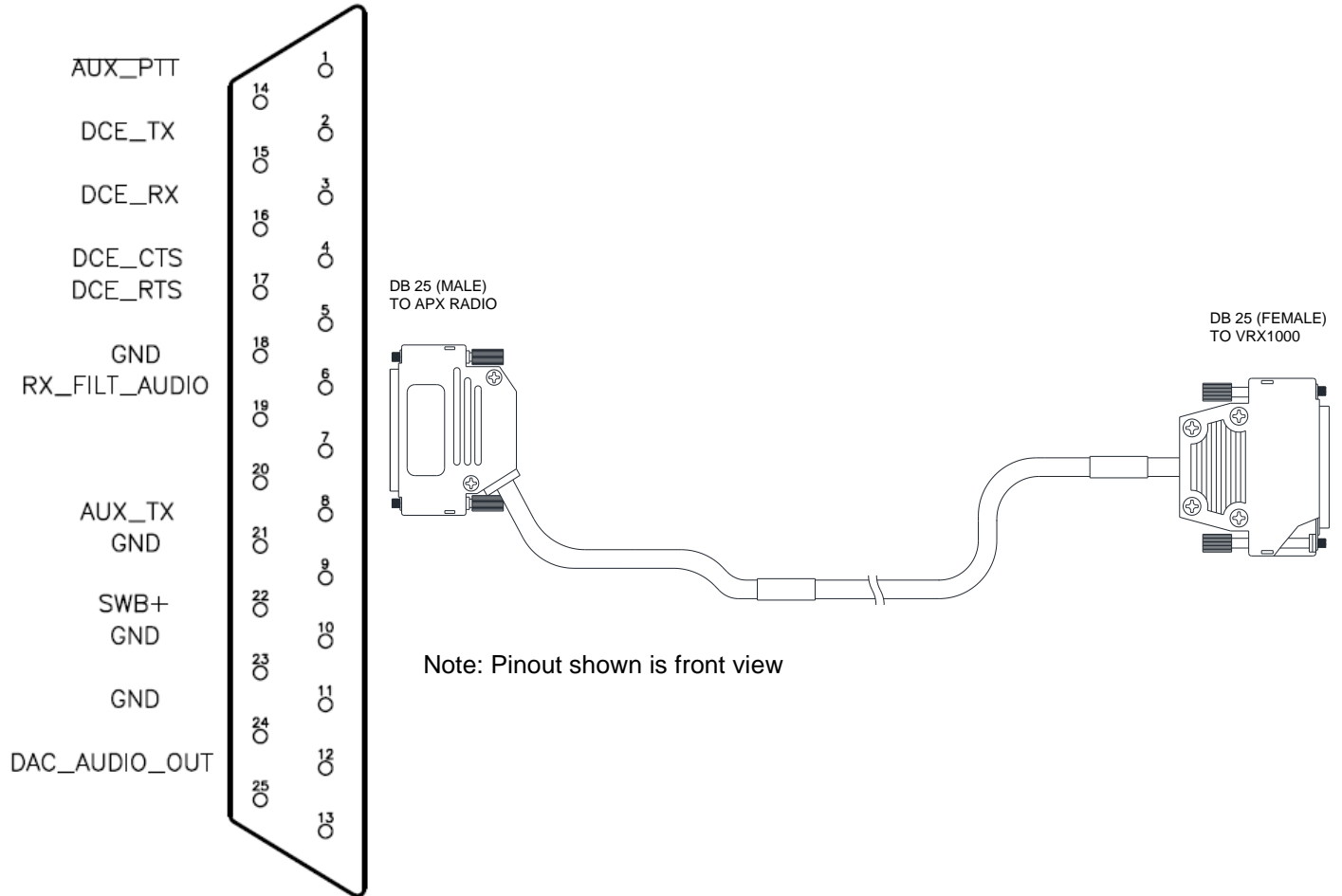

APPENDIX C- CABLES BY TYPE

RF Cables

Part Number	Order Code	Description	Length	Connectors	VRX1000 Models
7W087X11-01	VKN0002A	VRX1000 to In-band Filtering Cable	20" (50.80cm)	RA Mini UHF Male to RA Mini UHF Male	All In-Band Models
7W900X94-01	VKN0024A	MSU to In-Band Filtering Cable	20" (50.80cm)	RA QMA Male to RA Mini UHF Male	All In-Band Models with Non APX 8500

Control and Power Cables

Part Number	Order Code	Description	Length	Connectors	VRX1000 Models
1W087B01-01 7W087X07-XX	3ft: VKN0004A 5ft: VKN0005A 10ft: VKN0006A 15ft: VKN0007A 20ft: VKN0008A 25ft: VKN0009A	VRX1000 to MSU Cable	36" (91.44cm) Custom up to 300" (762cm) available	25-Pin Female to DB25 Male	Standard with all models
7W087X20-01	VKN0001A	VRX1000 Power Cable	216" (548.64cm)	6 -Pin female to flying leads	All models

Option Cables

Part Number	Order Code	Description	Length	Connectors	VRX1000 Models
1W087B05-01 7W087X08-XX	3ft: VKN0011A 5ft: VKN0012A 10ft: VKN0013A 15ft: VKN0014A 20ft: VKN0015A 25ft: VKN0016A	VRX1000 Y Control Cable Aux	36" (91.44cm)	DB25 Female to DB25 Male with DB15 Female	Standard with all in-band models, Optional for cross-band
7W083X09-01	VKN0028A	DVR-LX RF Switch Cable	12" (30.5cm)	15-Pin Male to 9-Pin Female	All in-band models
USB	VKN0003A	VRX1000 Programming / Re-flashing Cable	10' (304.8cm)	USB 2.0B to Mini USB	Ordered separately

APPENDIX D - VRX1000 ANTENNAS

Order Code	Freq. Band [MHz]	Type	Gain dBd
HAD4006A	136-144	Roof / Trunk Mount	0 (Unity)
HAD4007A	144-150.8	Roof / Trunk Mount	0 (Unity)
HAD4008A	150.8-162	Roof / Trunk Mount	0 (Unity)
HAD4009A	162-174	Roof / Trunk Mount	0 (Unity)
HAE6012A	380-433	Roof / Trunk Mount	0 (Unity)
HAE4003A	450-470	Roof / Trunk Mount	0 (Unity)
HAE4004A	470-512	Roof / Trunk Mount	0 (Unity)
HAF4016A	764-870	Roof / Trunk Mount	0 (Unity)

Glossary

Keyword	Description
AVRA	Automated VR Activation. VRX1000 option which permits automated activation of the VRX1000 by either using a VIP input on the MSU CH / DEK or a pin on the VRX1000 Auxiliary cable. Requires external logic / switch (not provided).
CH	Control Head.
Channel	The communication path between VRX1000 and PSU, or MSU and Conventional System.
Cross-band	VRX1000 operates in a different frequency band than all of the System frequency bands.
DEK	Direct Entry Keyboard.
DVRS	When a VRX1000 is interfaced with an MSU, the complete equipment package is referred to as a Digital Vehicular Repeater System (DVRS).
FCC	Federal Communications Commission.
Flat	VRX1000 components are provided individually allowing for a lower profile installation.
FRC	Futurecom Repeater Configurator. Programming software application for the VRX1000.
In-band	VRX1000 operates in the same frequency band as a system frequency band.
ISED	Innovation, Science and Economic Development Canada.
LOC	Local Mode: VRX1000 mode which allows repeated communication between the local PSUs and MSU. If configured, can also monitor activity on the selected MSU channel.
Mode	MSU – Talk group or channel VRX1000 – Determines the communication exchange capabilities between System Users and Local Portable Users; Can be set to OFF, LOCAL or SYSTEM.
MPE	Maximum Permissible Exposure.
MSU	Mobile Subscriber Unit.
P25	Standards for interoperable digital two-way radio products.
Primary	This VRX1000 is responsible for all communications in its coverage area. All other VRX1000s in the coverage area are in Secondary state.
PSU	Portable Subscriber Unit.
RF	Radio Frequency. Part of the general frequency spectrum 10kHz - 10,000,000 MHz
RX	Receive.
Secondary	This VRX1000 is not responsible for communications. There is a Primary VRX1000 already present in the coverage area.
Simplex	Data/voice can only flow in one direction at a time. VRX1000 can either transmit or receive at one time.
Stacked	VRX1000 components are stacked one on top of the other which requires more height for installation.

Keyword	Description
SYS	System Mode: VRX1000 mode which enables repeated communication between the local PSUs, MSU and two-way communication with Dispatcher and System PSUs.
TG	Talkgroup: A group of radio users who communicate with each other by using the same communication path. For a Trunking System, the communication path between the MSU and the System is referred to as a Talkgroup. For a Conventional System it is referred to as a channel. Throughout this document, the term channel/TG will be used.
TX	Transmit.
VIP	Vehicular Interface Port.
VR	Futurecom line of Vehicular Repeaters. It applies to one of the following products: DVR-LX, DVR and VRX1000.